

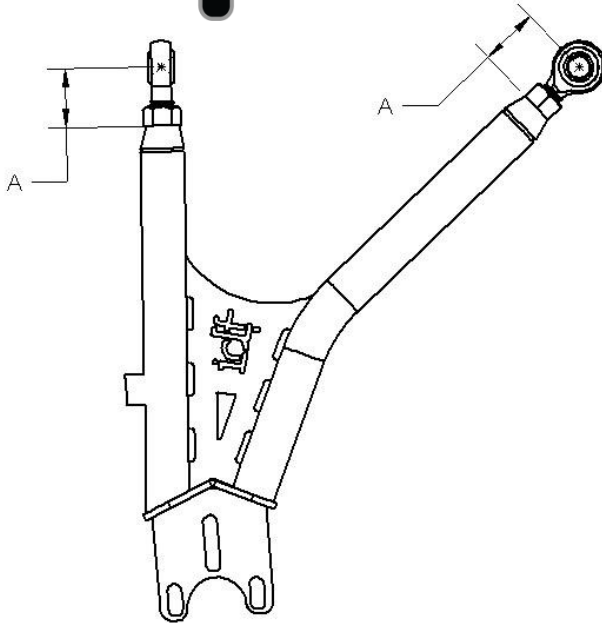

VW MKIV Tubular Control Arm Kit

IDF016



Rod End Adjustment:

A: 1 -11/16" (42.9mm)

- With the jam nut threaded onto the each rod end, the rod ends are to be threaded into the control arm to the approximate length above. (they may require additional adjustment during installation in order to fit the sub-frame)
- A pair of same size misalignment spacers gets inserted into each side of the rod ends to match the factory bushing width. (The Longer spacers go in the rod end toward the front of the vehicle)
- The Ball Joint Mounts on top of control arm with the provided hardware, Slotted holes provide camber adjustment and compatibility with TT/R32 and standard VW MK4 models
- Jam nuts must be tight before use
- Do not lubricate supplied rod ends, doing so may destroy the Teflon liner and may cause premature wear
- Do not use control arms as a vehicle jacking point

* This Product is not "intended" for street use

Innovative Design & Fabrication LLC
6354 Lincoln Highway West
Thomasville, PA 17364
717-779-7677
INNFAB.com